

LD8000

Trace Nitrogen in Argon or Helium analyzer

DESIGN REPORT_{v2}

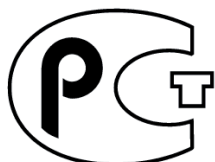

The need of trace nitrogen in argon or helium analysis in the industry is not something new. Many instruments have been and still are on the market to achieve such measurement for different type of applications. The most popular use is without any doubt in air separation industry for the production of argon.

The demand and the production of gas more and more pure require good analytical instrumentations. It is even more the case for the measurement of nitrogen. Small leakage, dead volume, change in temperature, bad accuracy, etc can all cause big headaches.

In this document, information about the design of the LDetek LD8000 trace nitrogen in argon or helium analyzer will be described to explain how we achieve such good performance. Those results are also described to show that the LD8000 is now the solution for any applications that require such measurement.

Analyzer Components

> Plasma Emission Detector (PED)

Detection principle

The LD8000 is using a Plasma Emission Detector where the principle is based on a spectroscopic emission cell. This is actually not a new technique, but the unique design of LDetek in terms of frequency, intensity as well as the mechanical and electrodes conception make the system very stable and efficient.

A luminous phenomenon, called electroluminescence, is created and is used as emission technique to quantify the nitrogen analyte. A plasma is created with the argon or helium flowing in the cell and when concentration of nitrogen changes, spectral lines emission change as well. The light is then directed in an optical filter that will discriminate the spectral lines. At the end, a photo-diode will convert light to current to make a proportional electric signal of nitrogen in the sample.

With its unique design, LDetek achieves unsurpassed performance that provides now a reference trace nitrogen in argon or helium analyzer.

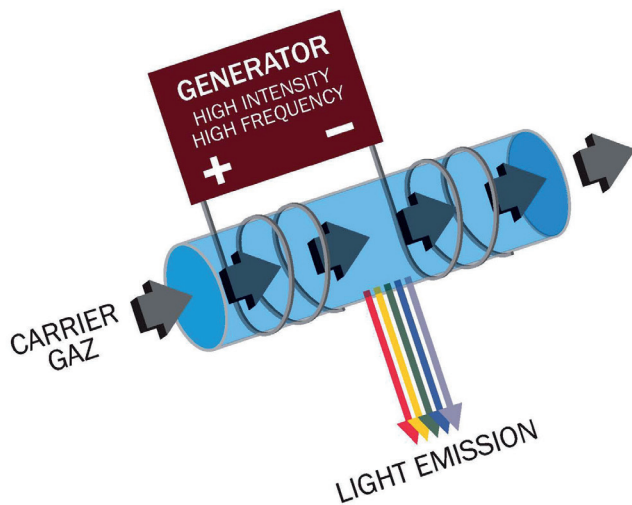

Figure 1: Plasma detector principle

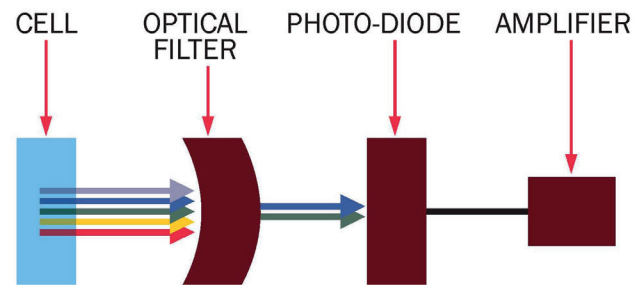

Figure 2: Light to current transformation

Plasma Cell

The cell of the PED is generally made of quartz. The material used has strong UV transmission properties. It is also durable, inert and heat resistant.

LDetek plasma detector has a specific cell design that provides a stable plasma. This unique conception will help getting low noise and good sensitivity when nitrogen is flowing in the detector along with the argon or helium. The wall cell design made of quartz combined with specific electrodes shape and inlet/outlet flow path configuration are some of the key parameters that give the performance of a PED.

Plasma Generator

The plasma generator is also quite important. Its specific voltage, frequency and current make the glow discharge in the cell very stable. The combination of the cell design and generator is critical in such application. LDetek has developed a perfect combination to get a stable light emission from the plasma. The components of the generator are well proven to be efficient and resistant over the years.

The generator is also based on a duty cycle controlled system that extends lifetime of the cell. The cell is put ON and OFF on a specific frequency and period to help the system to give the performance desired as well as decreasing the degradation of the detector.

Optical Filter and photo-diode

Optical filter is made specifically for LDetek specifications with properties to avoid interferences, temperature drift, loss of sensitivity and wavelength shifting over time. The wavelength, size, transmission lines and material are all critical characteristics that need special care to obtain such good performances.

The photo-diode will then convert the light out of the filter to current that is proportional of the amount of nitrogen in the sample. An electronic circuit designed by LDetek is then used for precision treatment of analog signal coming out of the photodiode.

Even if it sounds straightforward, LDetek has a unique way to install and align all items together. LDetek established rigorous procedures in a way to achieve high and same performances for each unit.



Figure 3: Plasma Detector module in the LD8000

> FLOW CONTROL

Flow management in such analyzer is critical in terms of dead volume and leakage. It is important to have a flow control device that will not introduce air and dead legs in the system. The LD8000 has an operating range as low as 0-1 ppm with a few ppb as detection limit. Conventional Mass Flow Controllers (MFC) is not suitable for such analysis. Since air is made of 78% of nitrogen, the chance to have some nitrogen introduced in the system with MFC is too high.

LDetek has designed its own flow control system to avoid air infiltration by the flow control device. The instrument can work with a flow as low as 25 cc/min and have a quick response time without apparition of dead volume.

Micro-Valve

LDetek have worked to develop a valve that meets the performances requirement. This miniature valve has a very small orifice size and offers ultra low flow rate. Since the LD8000 can work on relatively low flow, this valve design does not introduce delay or drifting problems.

Standard valves (figure 5) introduce "spikes" in the reading caused by dead volume located inside the valve. Measuring in so low concentration can be a big problem when having nitrogen released after calibration or upset condition in the sample.

With the LDetek micro-valve performance (figure 6), this problem is avoided and stable reading is obtained after any changes of concentration.

The inlet pressure can range from low as 4 PSIG to 30 PSIG without reading fluctuation. With an optional pump offered by LDetek, the instrument could work in even lower pressure.

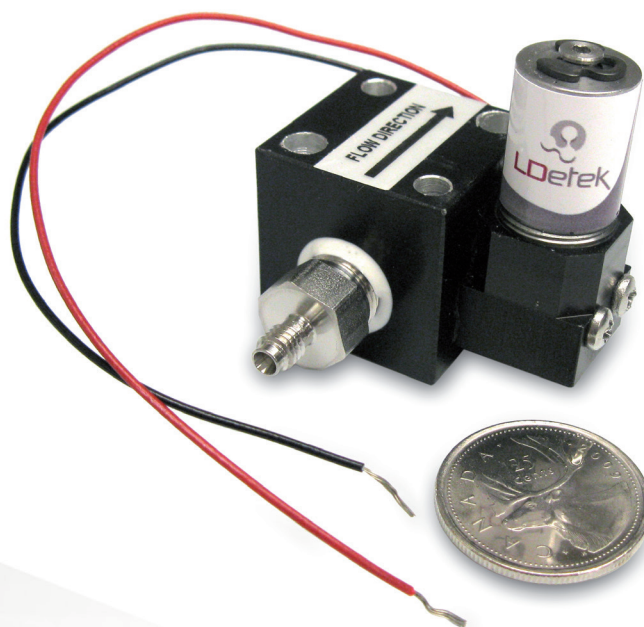

Figure 4: Micro-Valve for sample control

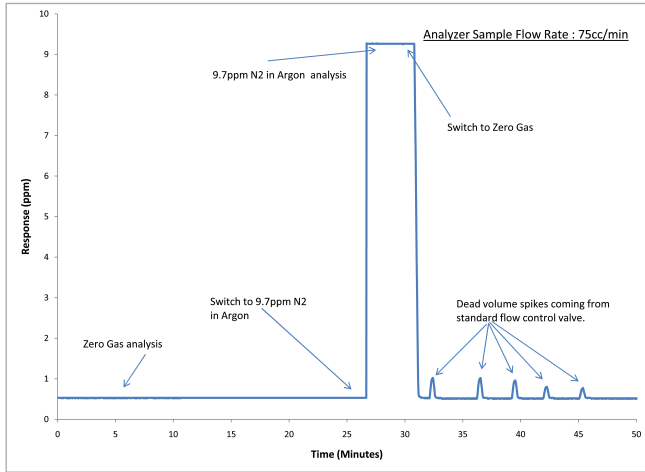

Figure 5: Standard valve performance

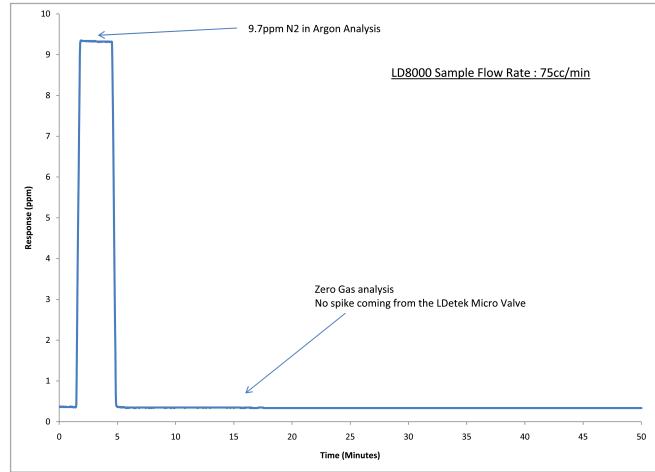

Figure 6: LDetek valve performance

Flow Transducer

The flow transducer is the biggest source of contamination for such analyzer. To avoid any problem with such device, the transducer is installed at the end of the flow path after the detector and is connected to the microcontroller unit to give information to the micro-valve to control a stable flow.

So why not using a MFC after the detector? That would avoid any chance of contamination or leakage? Actually, the PED must work at atmospheric pressure and it must not be pressurized. Since the PED is a cell made of quartz, it can break with a backpressure coming from the vent. Furthermore, you want to keep a constant pressure in the detector to get a stable plasma.

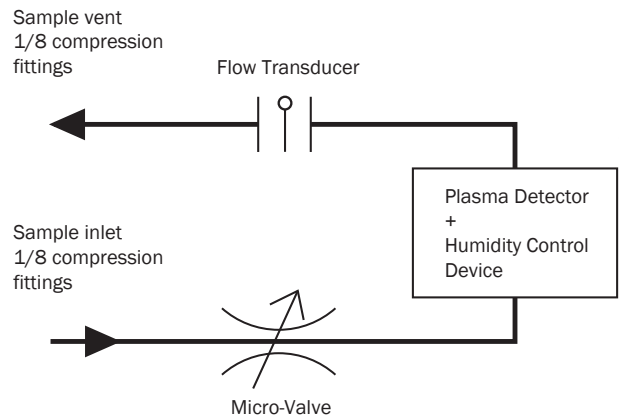

Figure 7: Flow path of the LD8000

> NO NEED OF ZERO CALIBRATION GAS !

An option is available that avoids the need of a pure reference gas to make the zero calibration. The LD8000 can be designed in a way that components are added inside the analyzer to generate zero gas.

Only the sample gas is connected to the instrument and zero calibration can be achieved. A valve's system is used to change the flow path to the detector. During zero calibration, the sample goes to a small gas purifier to get pure argon or helium.

There is no consumable in such configuration. Since the integrated gas purifier is used only during zero calibration and the valve system isolates it, the lifetime of the purifier is extended. Such system will save the needs of pure argon supply, gas regulator, piping, external purifier, bypass valve for the purifier, etc. The payback is quite evident!

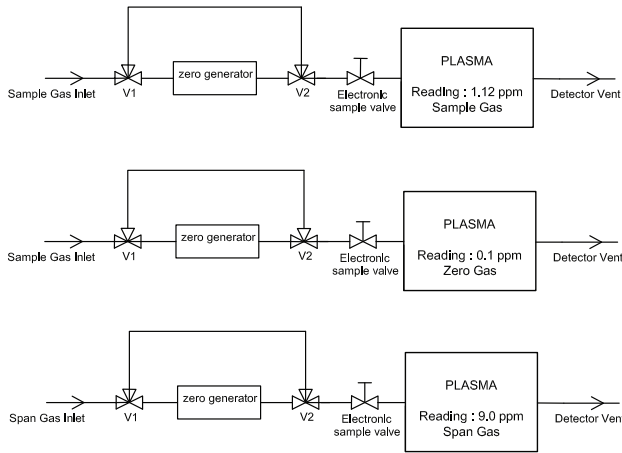

Figure 8: LD8000 with integrated zero calibrator

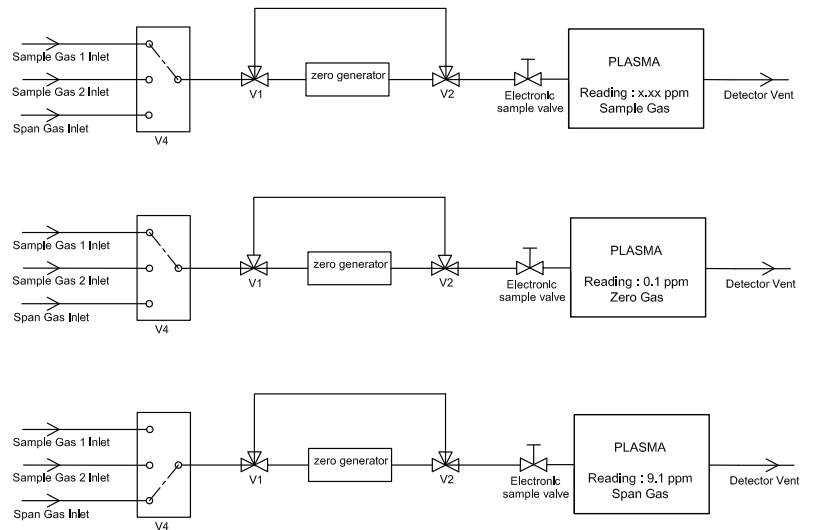

Figure 9: LD8000 with integrated zero calibrator & stream selector

> HUMIDITY CONTROL DEVICE (HCD)

Moisture is the worst « enemy » of nitrogen in the plasma. First of all, its emission wavelength is closed to nitrogen and some interference can occur. Furthermore, the level of energy available in the plasma is more consumed by H₂O than N₂. That reduces the light intensity of nitrogen ending by a loss of sensitivity.

In each LD8000, a Humidity Control Device is included in the detector module. This device introduces a constant amount of H₂O and other chemical vapors compounds in the detector to stabilize the influence of the moisture on the measurement of N₂. With the combination of the moisture trap installed outside of the cabinet on the sample line, the analyzer becomes stable at any variation of humidity in the sample.

> MAINTENANCE ?

No maintenance is required in the analyzer. The detector is a non-depleting type device as well as the other components inside the cabinet. Same for the flow control system, however if a defective part needs to be changed, no need to change a complete and expensive flow module or MFC (Mass Flow Controller). You can replace only the micro-valve or transducer.

The unit has been designed in a way to make life easier if parts need to be changed. No need to send back the instrument to factory. Any kind of parts, including the detector module, can be replaced on site by a technician.

The moisture trap installed outside the analyzer should be replaced or regenerated every year to get the best performance in stability and accuracy of the LD8000.

Analyzer Performance

The design of the LD8000 brings outstanding performances for the market demand. Even if this analyzer is used for ppm measurement, we get stability, accuracy and noise level for ppb analysis. With the design described above, some tests have been done to show the performances in different situations. Those performances have been tested with argon sample, since it is the most popular application on the market.

> RESPONSE TIME

The LD8000 has a fast response time to ensure a good purity control in the different applications of such analysis. However, such good result is always dependant of the installation along with the instrument. The stream selector system is critical to be able to achieve such good response time. We strongly suggest to use the LDGSS from LDetek which has been designed specifically for such application.

Figure 10:
*LD8000 Reponse time

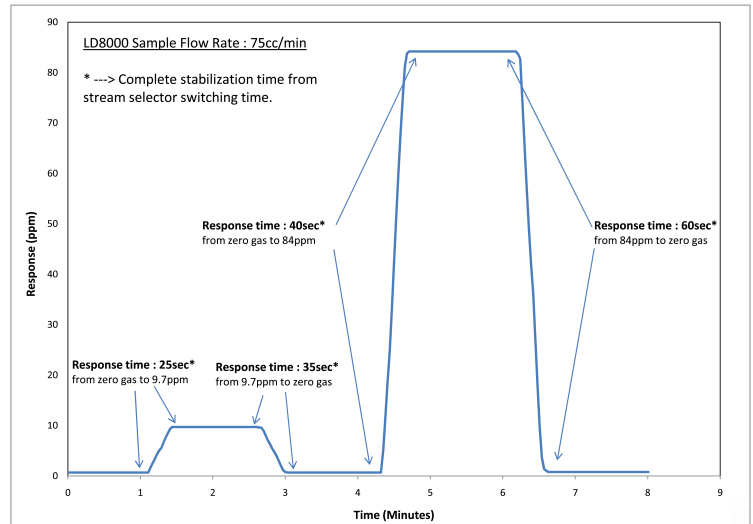

> NOISE

The electronic for the acquisition of the detector has been designed to avoid any noise that could influence the reading of the analyzer. But more importantly, the design of the detector itself is very important to minimize the noise as much as possible. The position of the optical filter along with the photo-diode is critical to get the specification of the LD8000. Bad response of those components means electrical gain increase to achieve the measurement desired and at the same time the noise level will be amplified. When mounting the detector, special care is done by LDetek specialist.

The amplifier board used to manage the signal from the photo-diode was also particularly well designed. This board takes very low voltage to amplify it on a scale up to 0-10 volts.

Figure 11:
*Noise level acquired on the analog output with a sample gas of about 0.104 ppm

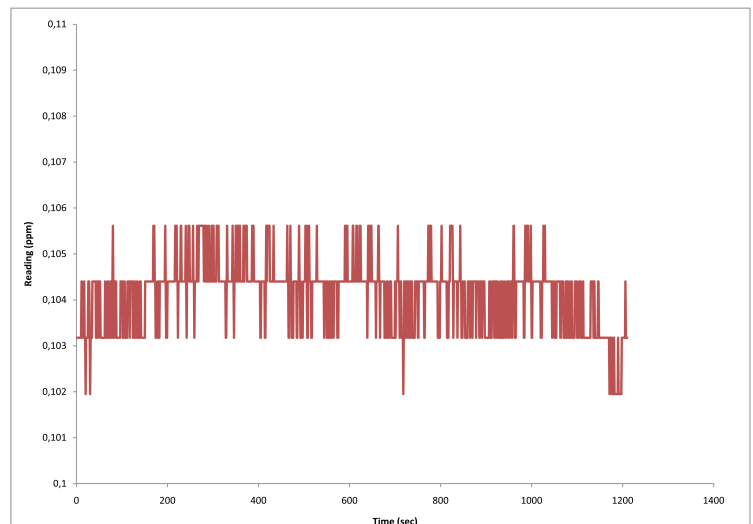

* Note:

This result has been obtained in LDetek facilities with the LDGSS stream selector device with a well purged system according to LDetek standard methods.

> STABILITY

Stability of the analyzer has been evaluated through a few hours period. Temperature variation has been caused to show the stability of the reading even with an unstable temperature environment. Those variations have been done on the analyzer itself and not on the whole system installation which can be different from site to site.

With a deviation of 4.4 Celsius (31.6 to 36 degrees) on a 36 hours period, the reading has moved down from 300 ppb to 280 ppb. This slight variation gives a 4.5 ppb / Celsius change. Considering that most of the installations are temperature controlled, no temperature effect will be observed. Moreover, the resolution of the analyzer is 10 ppb and slight temperature variation will not be seen by the software reading.

Stability has been evaluated on a 24 hours basis with stable environment (figure 13). The drift observed is less than 2 ppb.

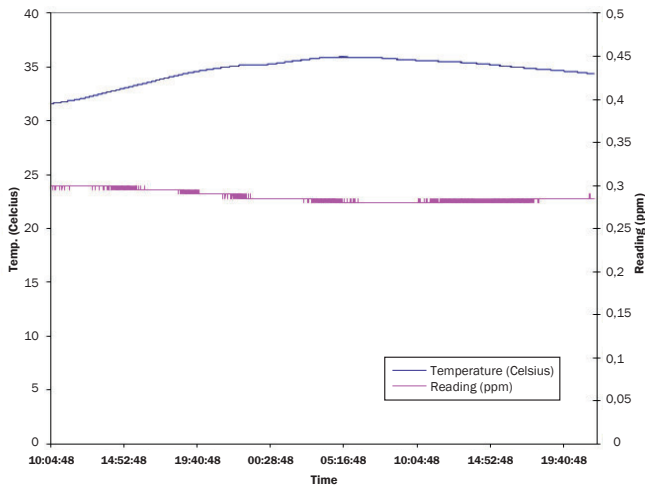

Figure 12: *Signal versus temperature

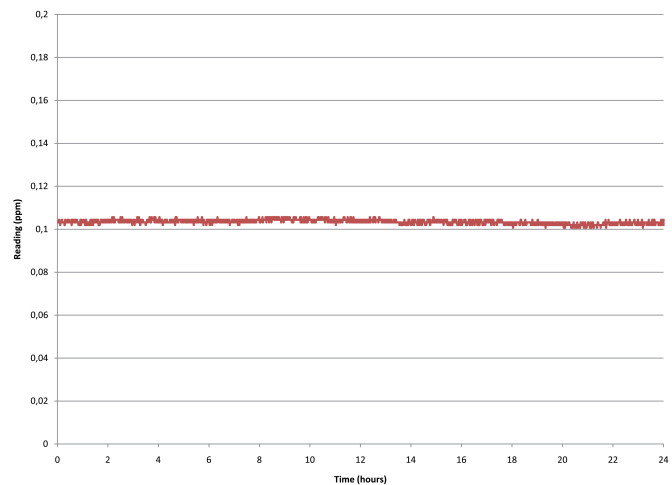

Figure 13: *24 hours stability on stable environment

> LINEARITY AND ACCURACY

Special care has been made on the linearity of the system. Knowing that existing instruments on the market do not offer linearity on the complete range of 0-100 ppm, LDetek has improved its detection system to be sure that working and calibrating the instrument on the range 0-100 ppm will offer the best performance.

On figures 14, calibration of the instrument has been done with a zero gas going through the LDP1000 gas purifier and the same dilution system for the different concentrations measured.

We have also made step changes in low concentration to show the accuracy of the instrument. Figure 15 demonstrates that a 10 ppb step change is easily detectable by the LD8000. Measuring pure gas on the range 0-1 ppm is more and more popular and such performance is appreciated from gas producers.

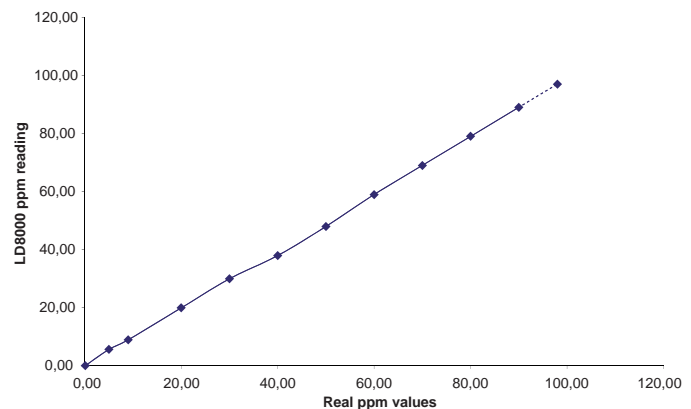

Figure 14: *LD8000 linearity on 0-100 ppm range

* Note:

This result has been obtained in LDetek facilities with the LDGSS stream selector device with a well purged system according to LDetek standard methods.

> DETECTION LIMIT

Referring to the noise of the LD8000 from figure 11, we get maximum 3.6 ppb peak to peak. Using the standard deviation method, we have used 15 consecutive points where we get the maximum peak to peak noise. Five times the standard deviation gives a LDL of 4.4 ppb.

This kind of instrument is mostly used for concentration higher than 100 ppb. The LDL is low enough for all Air Separation Unit or glove box application.

If LDL lower than that is required, LDetek is manufacturing the LD8000-Plus, which is the ppb version of the trace Nitrogen analyzer. We can detect lower than 1 ppb with signal to noise ratio very low. Please contact factory.

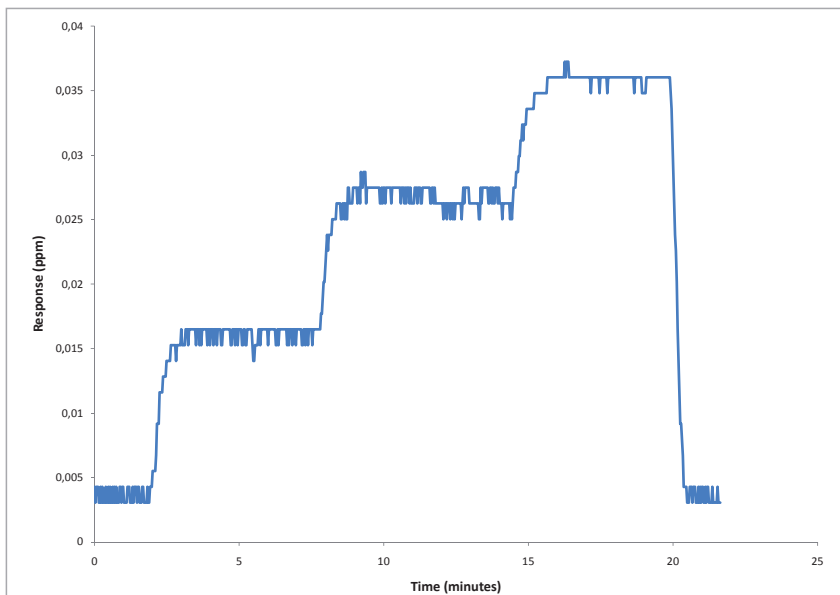

Figure 15:
*10 ppb concentration step changes

* Note:

This result has been obtained in LDetek facilities with the LDGSS stream selector device with a well purged system according to LDetek standard methods.

Conclusion

LDetek has put a lot of effort and time to introduce on the market a trace nitrogen in argon or helium analyzer with outstanding performances. We are proud to offer a reliable instrument that has been carefully designed with specialists having over ten years experience in trace nitrogen measurement and plasma emission detector.

For more information, comments or questions, don't hesitate to contact LDetek (info@ldetek.com).



Where innovation leads to success!

271 St-Alphonse Sud, Thetford Mines, (Qc), Canada, G6G 3V7
Phone: 418 755-1319 Fax: 418 755-1329 info@ldetek.com www.ldetek.com

©Copyright 2012 LDetek inc.