

# GC instrumentation and technology update

# Easy SamplePrep Add-On Software

Easy-to-use automated sample  
prep for 7693 ALS and Tray

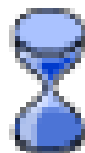

# What is it?

Graphically-oriented program to set up sample preparation methods

- derivatization
- internal standard addition
- serial dilution
- heating, cooling
- mixing
- ...



# Easy SamplePrep Resource Layout

Easy Sample Prep Resource Editor Version 2.1.30.0

Resource Name:

Resource Type:

Use Type:  By Volume  By Use

Usable Volume per Vial (µL):

Uses per Vial:

Display Color:

<< Resource Syringe Parameters

Syringe Parameters

Syringe Size (µL):

Number of Washes:

Number of Pumps:

Wash Volume (µL):

Draw Speed (µL/min):

Dispense Speed (µL/min):

Needle Depth Offset (0.1 mm steps):

Viscosity Delay (s):

Air Gap (% Syr. Vol.):

Vial Range:

Add Remove Replace Clear

<input checked="" type="radio"/> H2O	Chemical Resource	1500 uL/vial
<input type="radio"/> ISTD	Chemical Resource	4 uses/vial
<input type="radio"/> MeOH	Chemical Resource	1500 uL/vial
<input type="radio"/> Vial	Empty Container	1 uses/vial

Help Save Layout Print Layout Close

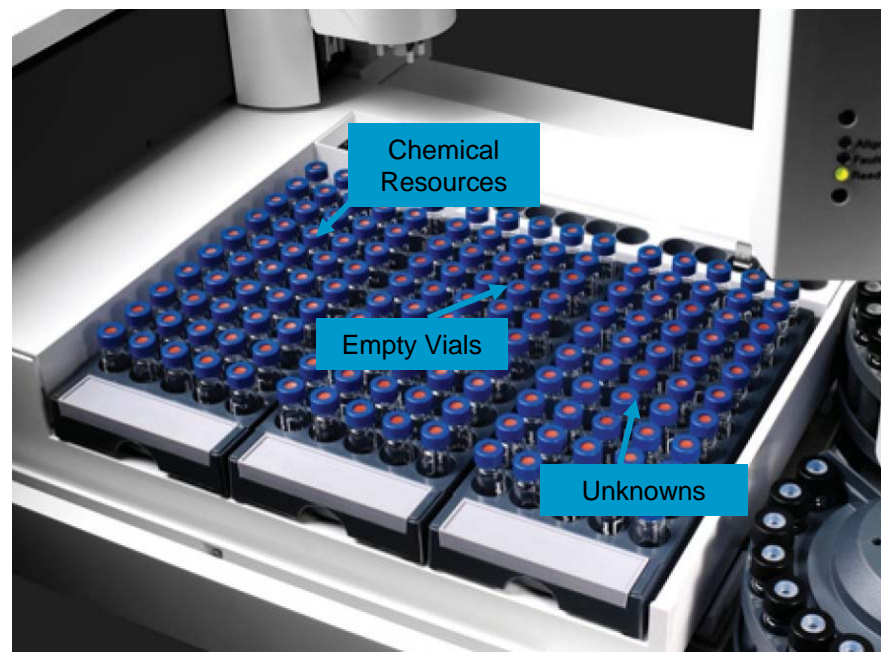

7693 ALS

## Resource Layout

- Specify chemical resources on tray
- Name resources
- Use colors to identify resources
- Edit default syringe parameters for resources and for each addition step

# Method Creation and Editing

## Drag and drop programming

The screenshot shows the 'Setup Method' window for an Agilent 7890A. The interface includes a title bar, a menu bar, and a main workspace. The workspace is divided into several sections:

- Actions:** A palette of icons for 'Add', 'Mix', 'Heat', 'Wait', and 'Select'.
- Program:** A visual flowchart showing a sequence of steps: four 'Add' steps in a row, followed by a 'Mix' step, a 'Heat' step, and another 'Mix' step.
- Steps:** A textual list of seven steps: 1. Add 250 uL of Sample (Front) to Sample Prep; 2. Add 50 uL of ISTD to Sample Prep; 3. Add 500 uL of H2O to Sample Prep; 4. Add 15 uL of MeOH to Sample Prep; 5. Mix Sample Prep at 1000 RPM for 0 min 5 sec; 6. Heat Sample Prep at 35 °C for 1 min 0 sec; 7. Mix Sample Prep at 1000 RPM for 0 min 5 sec.
- Resources Tracked By Use:** A table showing resource usage.
- Resources Tracked By Volume:** A table showing resource volume usage.

Buttons for 'Import', 'Export', 'OK', 'Apply', 'Upload from Instrument', 'Cancel', and 'Help' are visible at the bottom of the window.

Textual display of sample prep steps

Add Mix, Heat and Wait steps to create a custom sample prep program

# Ordering Information

- Easy SamplePrep Software Add-On Product Number (G7300AA)
- One license per instrument
- Requires at least a 7693A injector and a tray
- Recommended – second Injector with large-volume syringe, heater/mixer/BCR



# Data System Support

Supported GC Hardware Platforms	GC MP ChemStation	EZChrom	G1701EA GC/MSD ChemStation	MassHunter GC/MS GC/MS-MS
7890A 6890N/A/Plus with 7693 ALS	Release with B.04.02 SP1 (May)	3.3.2 SP2	No Plan	2011

# New GC interface kit (G3158C) for Agilent 7700 ICP-MS series





# G3158C Overview

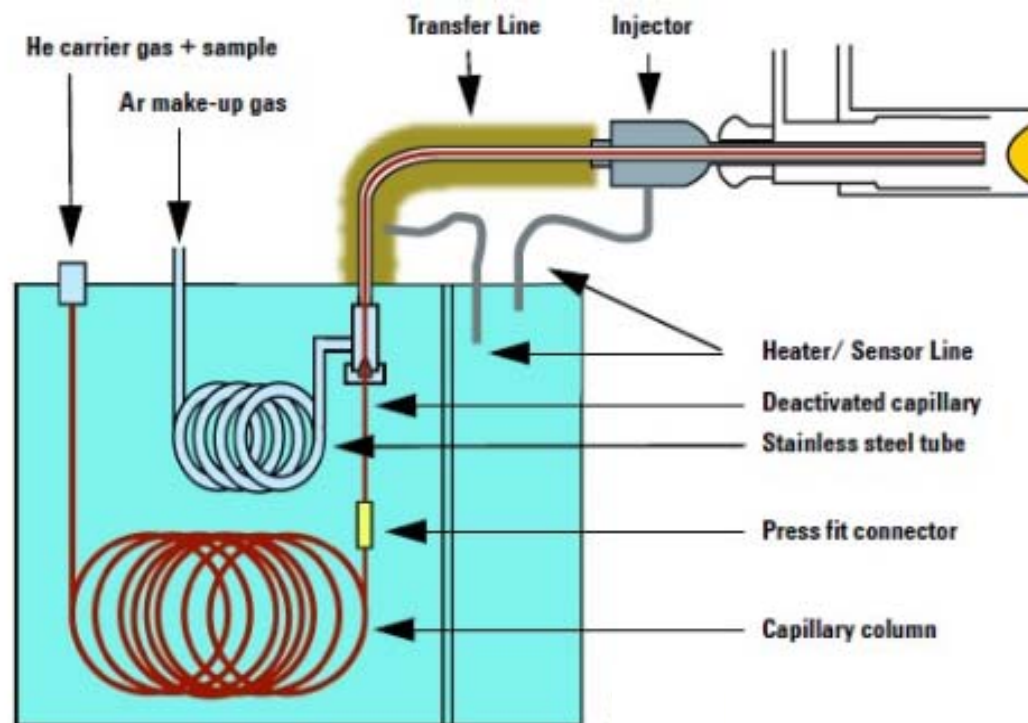

- Supported GC: 7890A GC, 7693 + 7683 ALS
- Support ICP-MS: 7700 Series  
(use G3158B for 7500, 6890)

# Product Overview - continued

Comparable performance and sensitivity compared to the previous version\*

Maximum transfer line temperature = 300 °C

Improved EMC

- Injector is retracted 10 mm compared to prior version
- Improved torch box grounding in the 7700 and replace center wall of 7700 (replaced as part of GC installation)

Shorter transfer line

A Sulfinert inner tube is inserted to the tip of the ICP injector for high inertness from the end of the column to the plasma

Pre-Heat inside the oven (not valve box)

Must use PCM instead of EPC for optional gas

\* Slightly elevated sulfur background compared to G3158B

# Simple connection and backed-off metal injector

The interface for 7700 (G3158C)

**NEW**

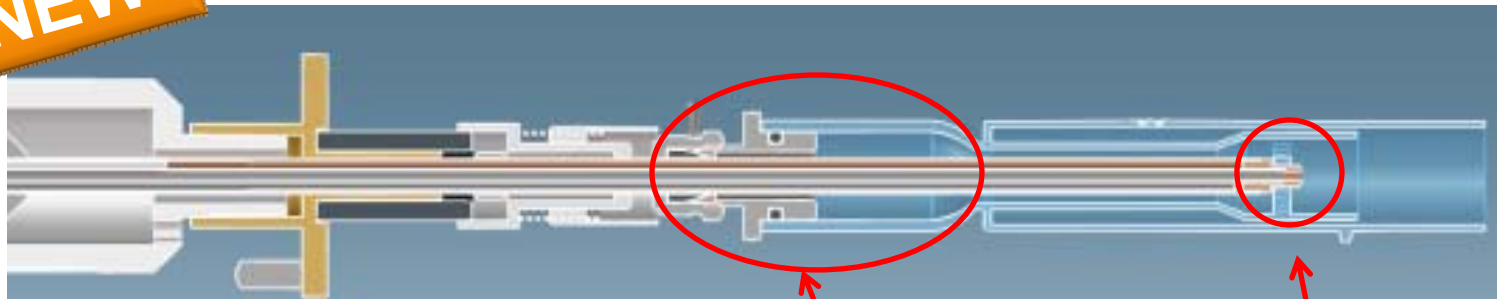

The interface for 7500 (G3158B)

**OLD**

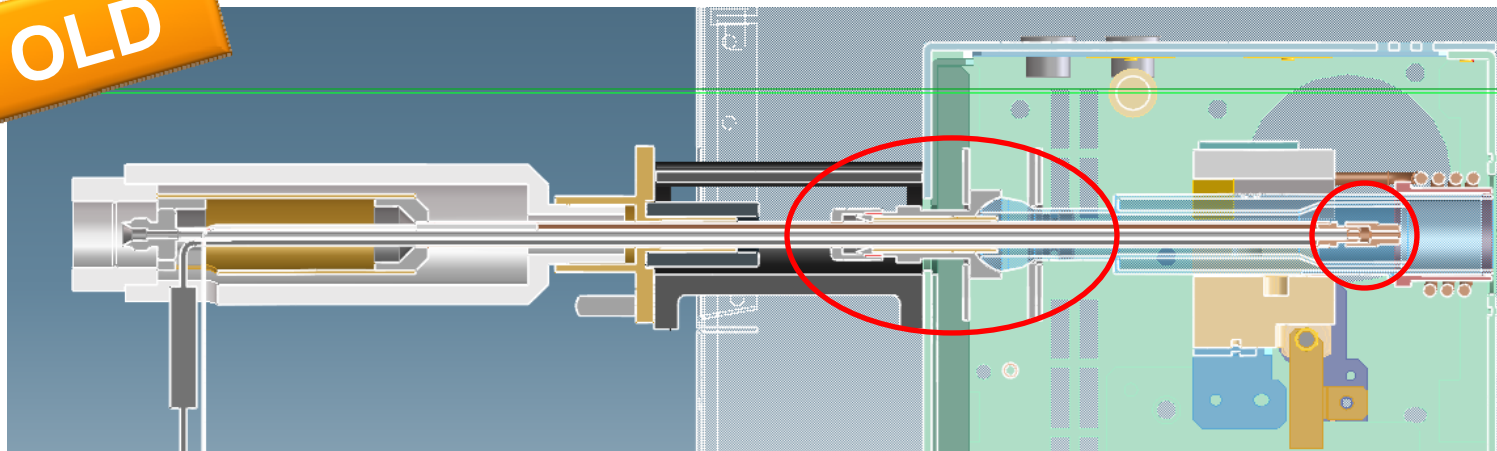

Simple Connection

Back Off metal Injector

# Easy install

Improved connection:  
Easy adjustment of the injector



O-ring connector makes it easy to  
align the injector to the torch

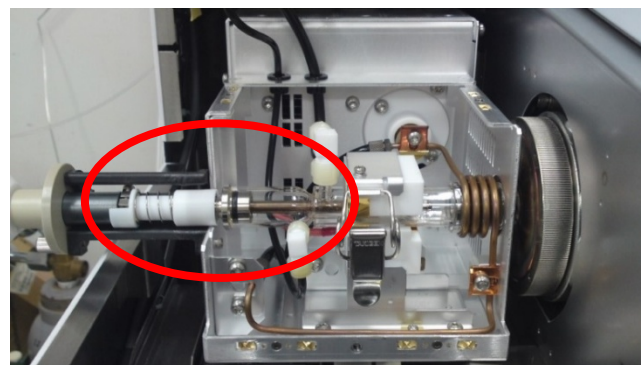

A docking station to hold and  
protect the interface when not  
connected to the ICP-MS.



# 25 ppb Polybrominated Diphenyl Ether predominant congener mixture (EO-5103)

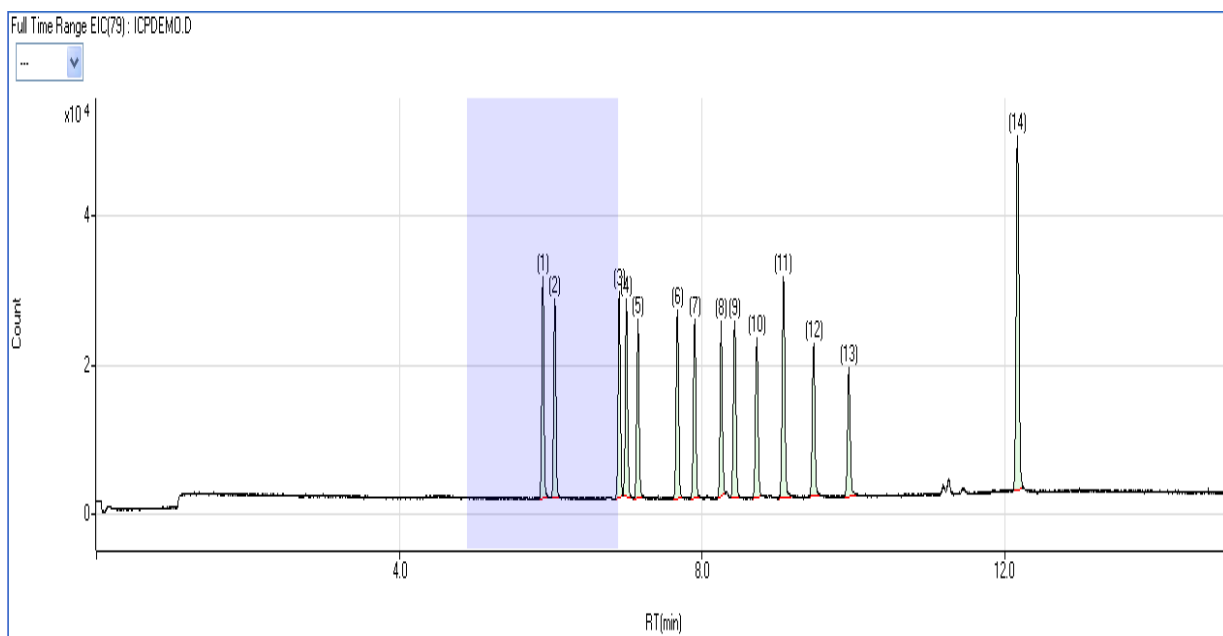

- |                                       |  |
|---------------------------------------|--|
| (1) 2, 2',4-TriBDE (BDE – 17)         | (8) 2, 2',3,4,4'-PentaBDE (BDE – 85)         |
| (2) 2, 4',4-TriBDE (BDE – 28)         | (9) 2, 2',4,4',5,6'-HexaBDE (BDE – 154)      |
| (3) 2, 3',4',6-TetraBDE (BDE – 71)    | (10) 2, 2',4,4',5,5'-HexaBDE (BDE – 153)     |
| (4) 2, 2',4,4'-TetraBDE (BDE – 47)    | (11) 2, 2',3,4,4',5'-HexaBDE (BDE – 138)     |
| (5) 2, 3',4,4'-TetraBDE (BDE – 66)    | (12) 2, 2',3,4,4',5',6-heptaBDE (BDE – 183)  |
| (6) 2, 2',4,4',6-PentaBDE (BDE – 100) | (13) 2, 3,3',4,4',5',6'-HeptaBDE (BDE – 190) |
| (7) 2, 2',4,4'-5-PentaBDE (BDE – 99)  | (14) DecaBDE (BDE – 209)                     |

## Method parameters

GC	
Injection	Split /splitless 1µl
Column	5m x 0.25 mm x 0.25 µm DB-5MS
Oven Program	80°C (1 min), 20 °C/min -> 320°C (5 min)
Carrier gas	He at 7 mL/min
Inlet Temp	260 °C
Transfer line temp	250 °C
ICP injector temp	280 °C
Additional Gas	No
ICP-MS	
ICP-MS model	7700x
RF Power	1250 W
Sample Depth	7 mm
Carrier gas	0.61 L/min
Aux Gas	1.5 L/min
Additional Gas	No
<b>DL</b>	<b>150 ppt (for Deca BDE)</b>

# 10 ppb organo-Sn standard

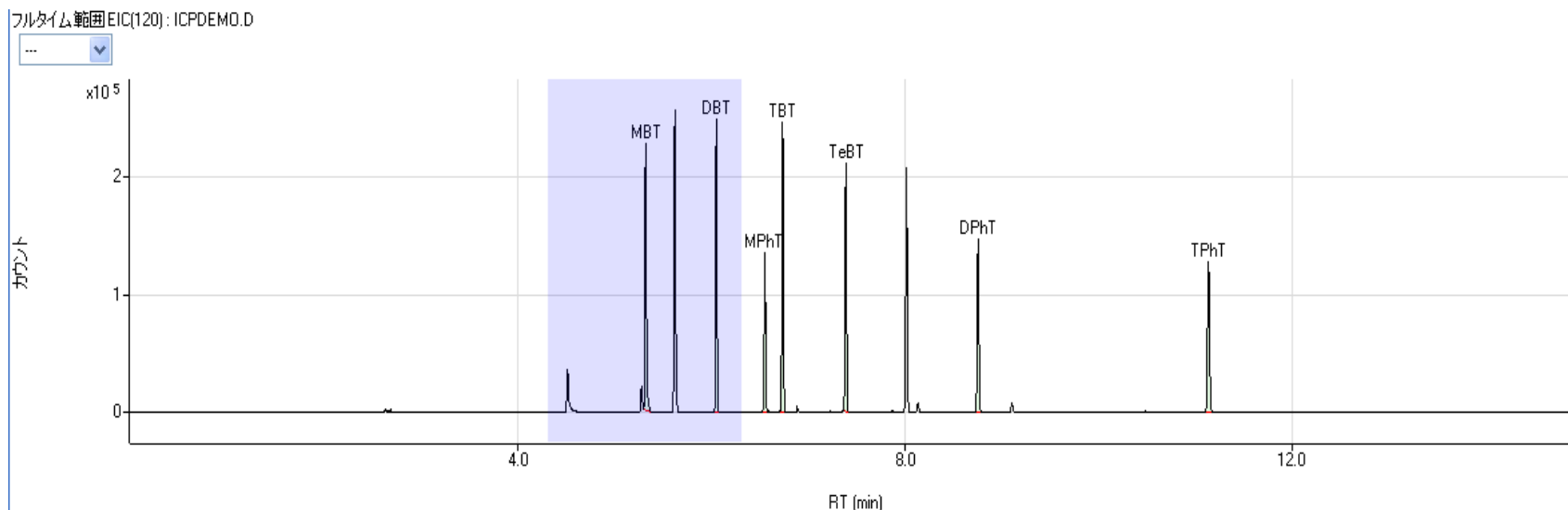

Method parameters

GC		ICP-MS	
Injection	Split /splitless 1 $\mu$ l	ICP-MS model	7700x
Column	30 m x 0.32 mm i.d. x 0.25 $\mu$ m HP-5	RF Power	1200 W
Oven Program	70o(1min) ~ 30o/min ~190 $^{\circ}$ C (0min) ~ 15 %/min ~ 270 $^{\circ}$ C (4min)	Sample Depth	8 mm
Carrier gas	He at 2 mL/min	Carrier gas	0.80 L/min
Inlet Temp	290 $^{\circ}$ C	Aux Gas	1.5 L/min
Transfer line temp	250 $^{\circ}$ C	Additional Gas	No
ICP injector temp	250 $^{\circ}$ C	<b>DL</b>	<b>5.9 ppt TBT S/N = 20384 (peak-to-peak noise)</b>
Additional Gas	No		

# Agilent's new **5975T** Transportable GCMS

Laboratory quality performance GCMS for out-of-laboratory applications



Agilent Technologies

ISC

VI01111 ##, 2008

# Agilent's Out of Laboratory GCMS

## Developing the best transportable GCMS

### Step One

Take the industry's best GCMS proven by the greatest number of customer references over the last 30 years

### Step Two

Integrate Agilent's new patented **low power** high efficiency Low Thermal Mass (LTM) column technology reducing the power requirement 46%, shrinking the footprint 38% and reducing the weight 35%

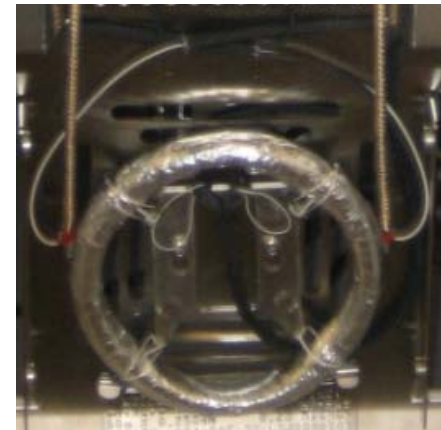



# Agilent's Out of Laboratory GCMS

## Developing the best transportable GCMS - 5975T LTM GC/MSD

### LTM technology overview

No practical limitations to capillary choices for GC/MS

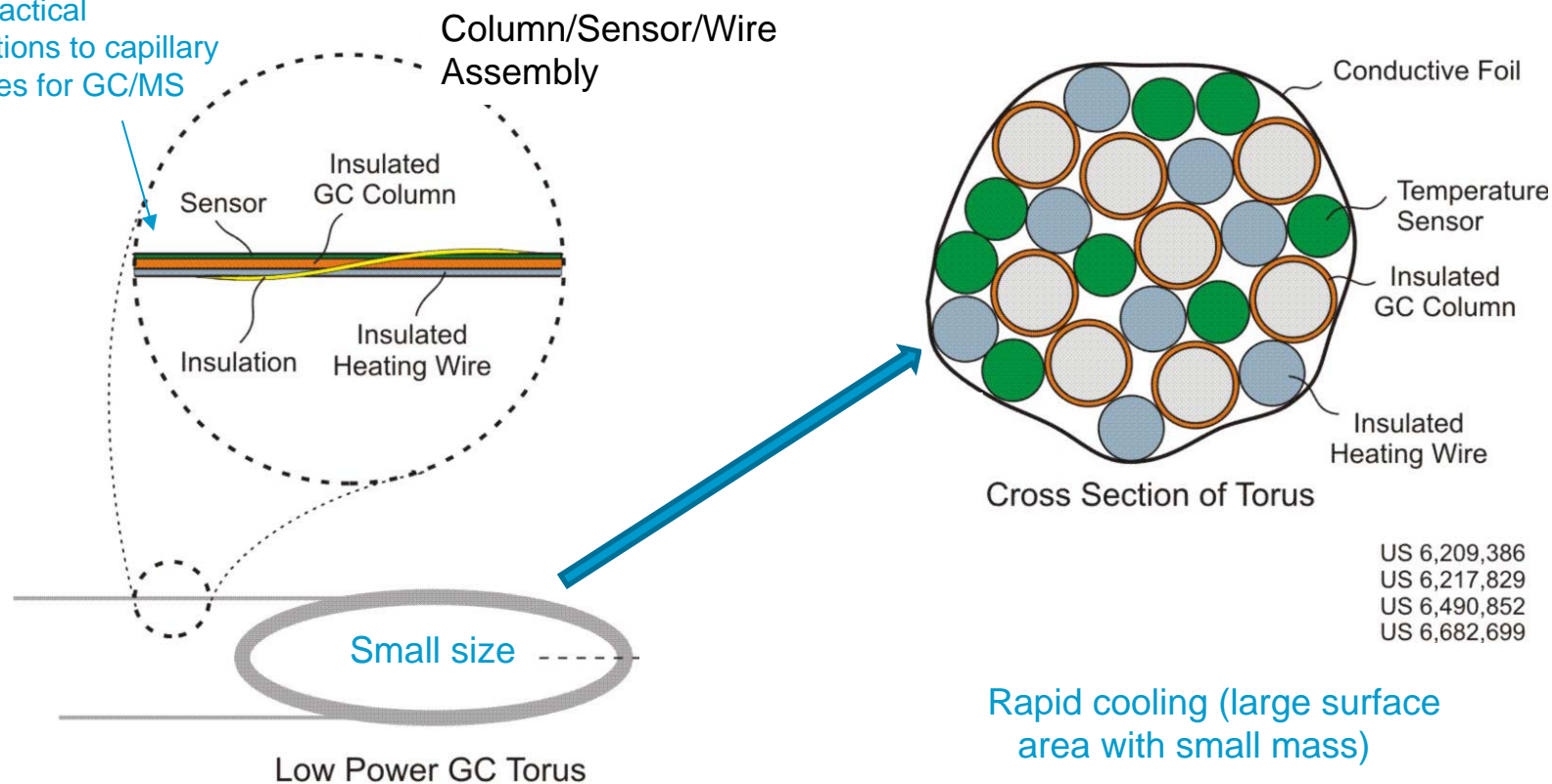

Efficient, fast temperature programming

# Agilent's Out of Laboratory GCMS

Developing the best transportable GCMS - 5975T LTM GC/MSD

## Integrating LTM technology

- Integrated guard column
- Front access LTM module for easy field replacement
- Standard S/SL injector
- Full Agilent EPC

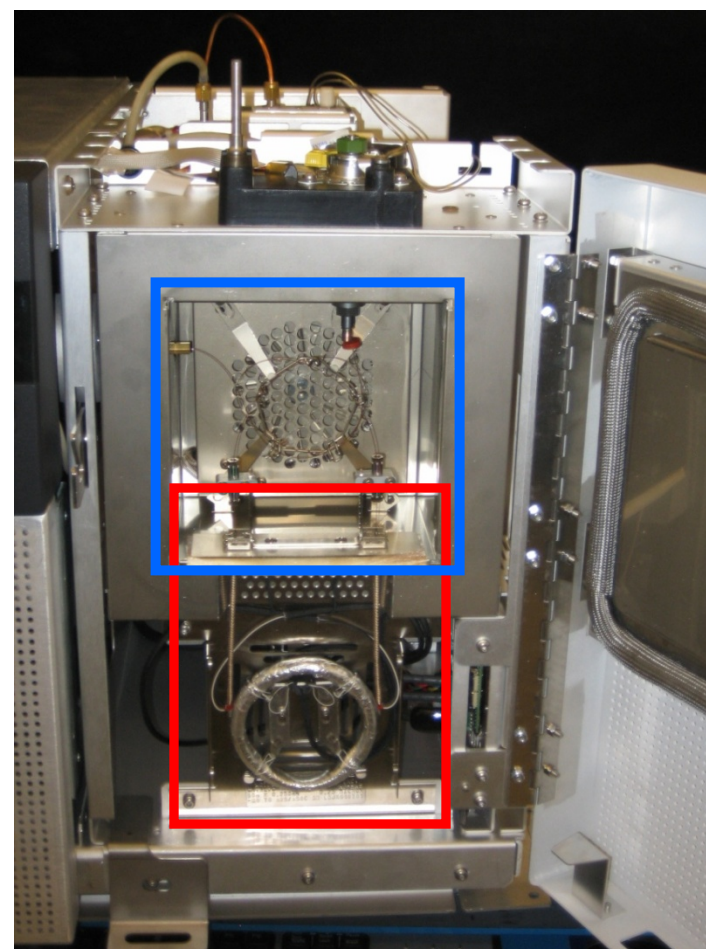

# Agilent's Out of Laboratory GCMS

Developing the best transportable GCMS - 5975T LTM GC/MSD

## The End Result

The industry's first high performing, laboratory quality GCMS capable of field deployment anywhere in the world!



### **5975T LTM GC/MSD**

*Transportable Laboratory Quality  
GCMS*

# Agilent's Out of Laboratory GCMS

Developing the best transportable GCMS - 5975T LTM GC/MSD

## Chemical Warfare Agents (CWA) Results

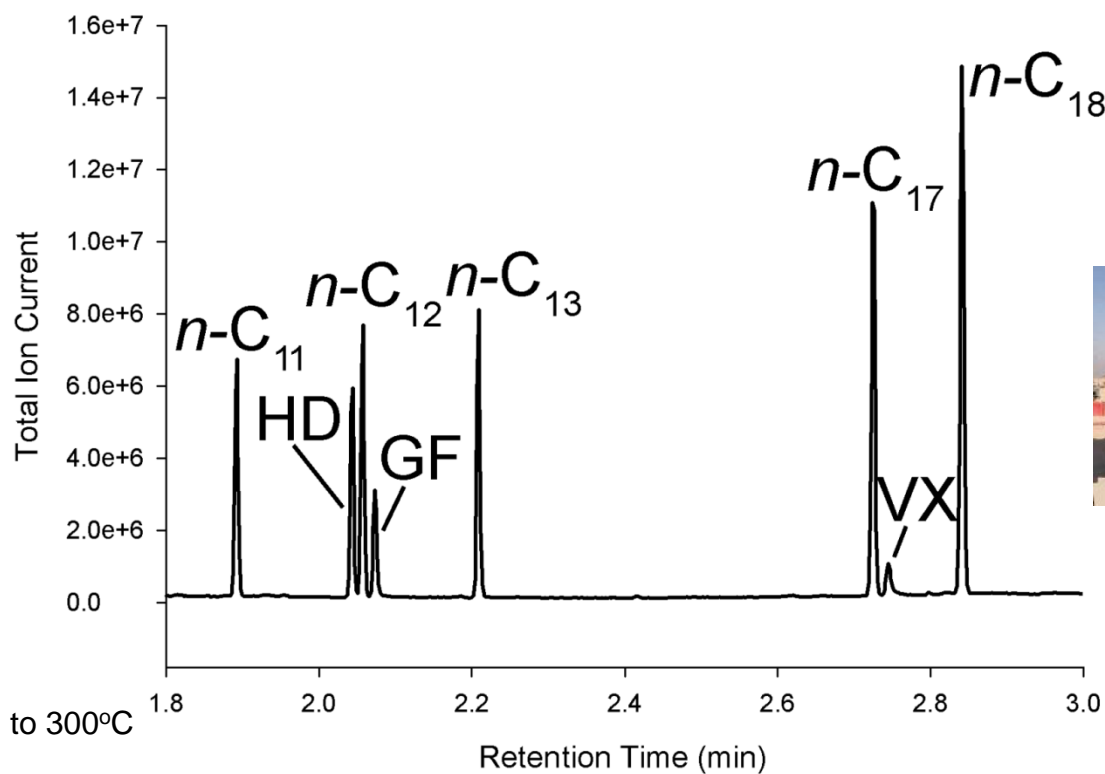

40°C 30s; 120°C/min to 300°C  
50 ng per analyte

# Agilent's Out of Laboratory GCMS

Developing the best transportable GCMS - 5975T LTM GC/MSD

## CWA Simulants by Thermal Desorption

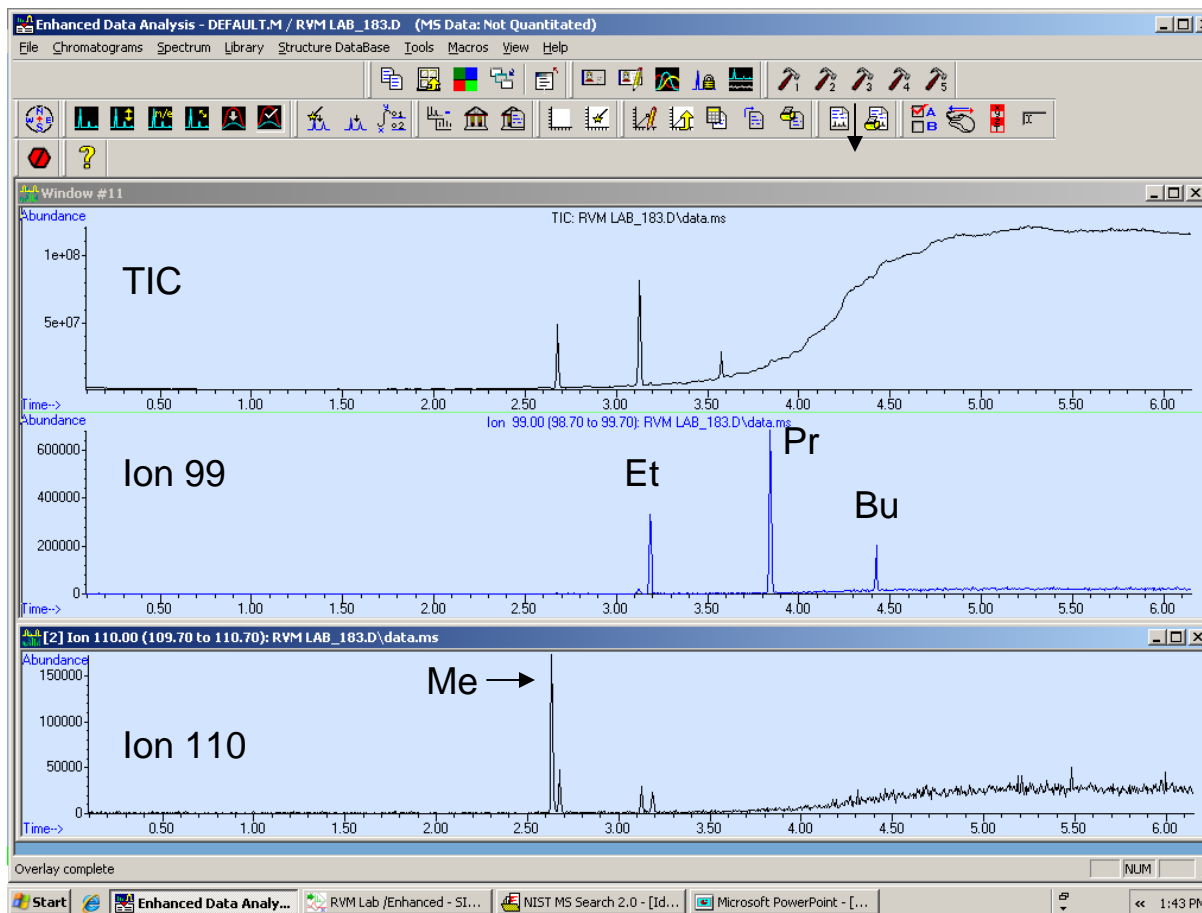

Markes Unity2  
Thermal Desorber

~180 ppb P(OR)<sub>3</sub>  
Sample 1 min onto  
Tenax TA @ 68 mL/min  
Prepurge 1 min  
Desorb 280°C, 3 min  
FT -10°C  
FT desorb 300°C 1 min  
TL, Valve 120°C  
LTM Oven 300°C  
MSD TL 230°C  
1 m x 0.32mm guard  
30m x 0.32mm x 1.0um  
DB-5ms column  
3.0 psi He  
TP: 50°C→300°C @  
60°C/min, hold 2 min

# Agilent's Out of Laboratory GCMS

Developing the best transportable GCMS - 5975T LTM GC/MSD

## CWA Simulant Vapors by SPME (SIM 99+110)

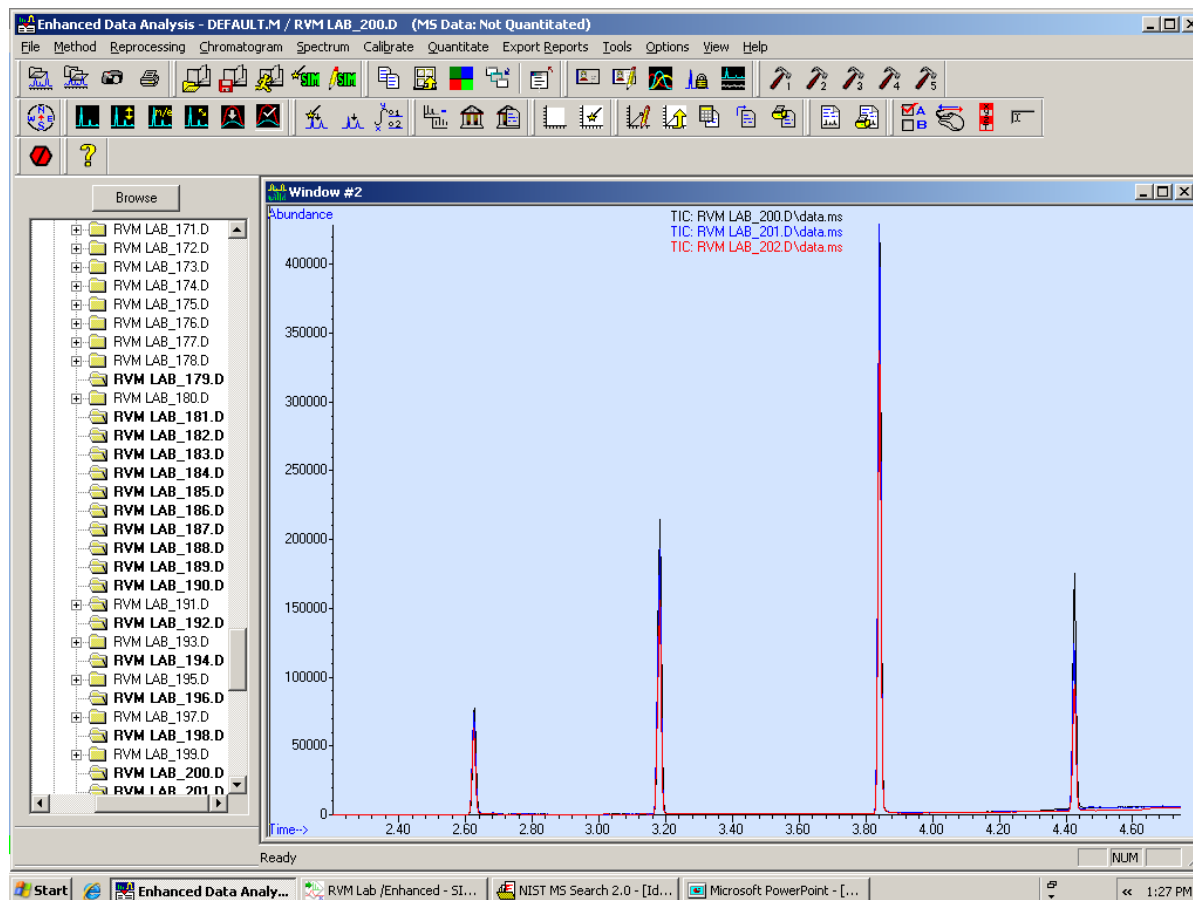

~180 ppb P(OR)<sub>3</sub>  
Sample 1 min with  
100 um PDMS SPME  
LTM Oven 300°C  
Injector 300°C  
MSD TL 230°C  
1 m x 0.32mm guard  
30m x 0.32mm x  
1.0um  
DB-5ms column  
3.0 psi He  
TP: 50°C→300°C @  
60°C/min, hold 2 min

Triplicate run

# Agilent's Out of Laboratory GCMS

Developing the best transportable GCMS - 5975T LTM GC/MSD

## CWA Simulants in Background Using SIM/Scan

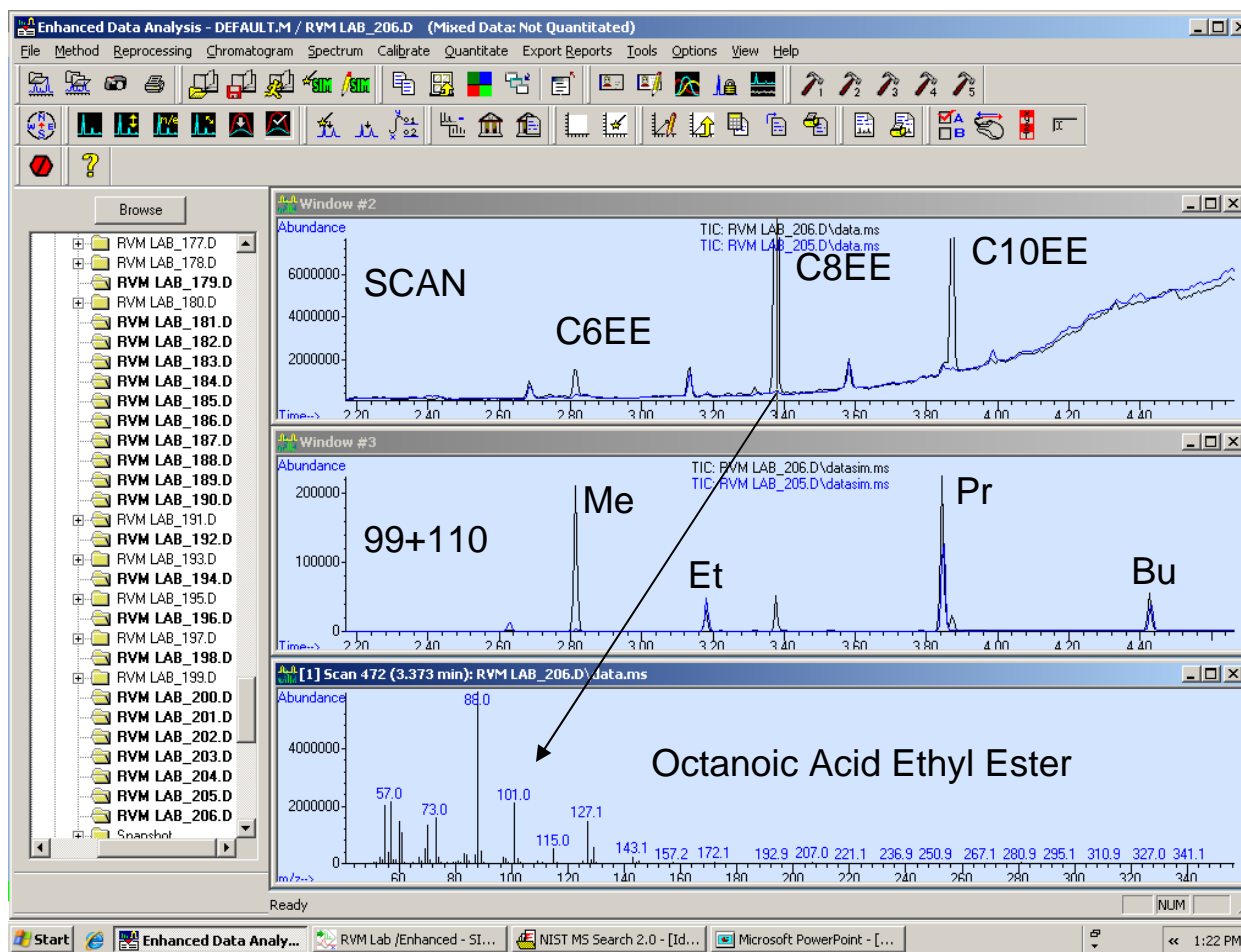

~180 ppb P(OR)3  
Sample 1 min with  
100 um PDMS SPME,  
then also with 60 min head  
space sampling of a heated  
Chardonnay sample

LTM Oven 300°C  
Injector 300°C  
MSD TL 230°C  
1 m x 0.32mm guard  
30m x 0.32mm x 1.0um  
DB-5ms column  
3.0 psi He  
TP: 50°C→300°C @  
60°C/min, hold 2 min

SIM/Scan  
SIM: 99+110  
Scan: 50-350 amu  
(4.5 scans/s → 4 scans  
over narrowest  
peak)

# Agilent's Out of Laboratory GCMS

## Developing the best transportable GCMS - 5975T LTM GC/MSD

### Identification in NIST Database

The screenshot displays the NIST MS Search 2.0 interface. The main window shows a mass spectrum for Scan 472 (3.373 min) with a base peak at m/z 88. The search results table is as follows:

Lib.	Match	R.Match	Prob. (%)	Name
R	909	931	88.4	Octanoic acid
M	903	919	88.4	Octanoic acid
R	901	917	88.4	Octanoic acid
R	753	821	2.28	Decanoic acid
R	749	837	1.92	Nonanoic acid
M	741	764	1.92	Nonanoic acid
M	740	762	1.39	Hexanoic acid
R	730	806	2.28	Decanoic acid
R	729	789	1.92	Nonanoic acid
R	725	807	0.84	Dodecanoic a
R	723	781	2.28	Decanoic acid
R	715	798	0.59	Heptanoic aci
M	714	786	0.57	Undecanoic a
R	712	769	0.57	Undecanoic a
R	710	726	0.57	Undecanoic a

The identified compound is Octanoic acid, ethyl ester. The interface also shows the chemical structure and a list of 10 largest peaks for the reference compound.



# Agilent's Out of Laboratory GCMS

Developing the best transportable GCMS - 5975T LTM GC/MSD

**Agilent's new 5975T  
GCMSD will be available  
for ordering in Q3 2010  
with shipments taking  
place Q4 2010**



## **5975T LTM GC/MSD**

*Transportable Laboratory Quality  
GCMS*

# Exciting Times

Thank You